

PAPER • OPEN ACCESS

Intelligent distributed module for local control of lighting and electrical outlets in a home

To cite this article: J. Andramuño *et al* 2021 *J. Phys.: Conf. Ser.* **1730** 012001

View the [article online](#) for updates and enhancements.



ECS The Electrochemical Society
Advancing solid state & electrochemical science & technology

239th ECS Meeting with IMCS18

DIGITAL MEETING • May 30-June 3, 2021

Live events daily • Free to register

Register now!

Intelligent distributed module for local control of lighting and electrical outlets in a home

J. Andramuño¹, E. Mendoza¹, J. Núñez², E. Liger¹

¹ Automation Department. Universidad Católica de Santiago de Guayaquil, Ecuador

² Department of Energy. Universidad de la Costa, Colombia

*Corresponding author: joselyneandramuno@gmail.com,
eduardo.mendoza01@cu.ucsg.edu.ec, jnunez22@cuc.edu.co

Abstract. This article proposes a control of lighting and electrical loads, suitable for smart homes, using embedded systems with low-cost wireless communication modules. The system is based on a distributed intelligent home automation architecture, to work autonomously or interconnect wirelessly to a larger system. It has a set of sensors that allow you to ration the use of electricity through automatic switching off the lights or electrical devices, allowing the lighting to be regulated. It has several modules that communicate to a central node wirelessly, and an interface based on a mobile application. UML and Petri Nets were used for the projection, modelling and validation of the system, its implementation was developed in C / C ++ language for 32-bit microcontrollers. Tests of the prototype showed stable behavior, fast communications and sufficient coverage for a single-family house, whose performance is higher to other similar works found in the scientific community.

1. Introduction

Home automation integrates a wide variety of fields and technologies related to automation, computer science and new communication technologies, with the aim of improving comfort, safety and energy savings in homes [1, 2]. There are still many challenges pending in the design of smart homes so that they satisfactorily meet their objectives, among these we could mention the integrated increase of home automation and security [2, 3], the reduction of energy consumption [4-7], monitoring of various health parameters [8], as well as caring for people [9].

The heterogeneity of equipment and diversity of technologies associated with home automation generate incompatibility between equipment and the formation of technological islands in the home [10, 11], preventing an adequate integration of the subsystems, which brings about a slowdown in development and generalization of home automation systems [12, 13]. Energy management is one of the integrated functions, which in addition to optimizing electrical energy consumption [14, 15], contributes to saving other household resources in order to make home automation user-friendly [16].

In the present work we propose the design of a wireless prototype oriented to the control of lighting and intelligent loads, based on 32-bit microcontrollers and low-cost devices, which constitutes part of a larger system, proposed by [17, 18]. The system is aimed at the control and regulation of lighting and the control of electrical loads in a home, for which three smart modules have been developed wirelessly interconnected. One of the modules has the master function and is called the master node (MN), while the remaining two modules take care of the lighting control and load control functions, and are called the control nodes (CN). Both control nodes are connected to the MN wirelessly. Furthermore, a dimmable led lamp, a socket, a remote control and a smartphone interface have been integrated into the system, as can be seen in figure 1.



For the projection and design of the prototype, the Unified Modeling Language has been used and for the simulation, verification and validation, the Petri nets. In the implementation of the system, the C / C ++ language of the Keil development platform was used[19].

2. Analysis of the lighting and charging control system

This section describes the elements, characteristics and functions that are part of the system, both software and hardware, and that are the basis for starting the projection and design of the prototype.

2.1. Description

The general operation begins with the energization of the devices that are part of the prototype. All nodes start their own script and load configuration instructions, after which the MN starts to recognize the different nodes, including the interface with the smartphone. The MN keeps waiting for the commands coming from the different devices of the system: User interface (smartphone), remote control, lighting CN and the load CN. Each of the commands received by the master node is associated with a specific algorithm to execute the required operations. The MN has a microcontroller with greater resources and processing capacity than the CNs, so the MN will execute the algorithms with the highest processing requirements. The flow chart in Figure 2 shows the sequence of operations.

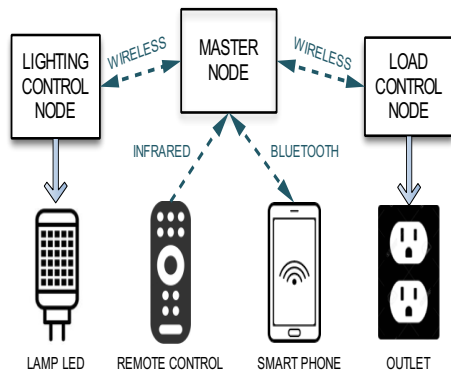

Figure 1. General structure of the prototype

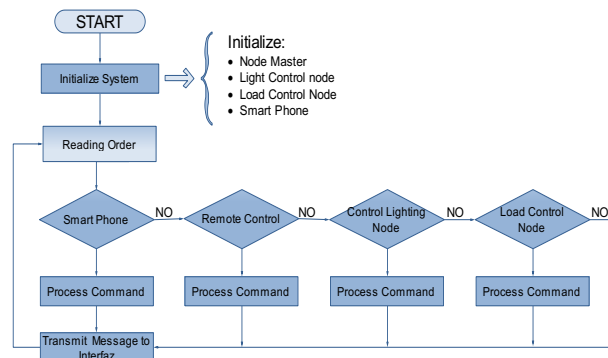

Figure 2. General Flowchart

2.2. Characteristics

The home automation prototype is composed of the elements shown in Table 1.

Table 1. Elements of the home automation prototype

Order	Hardware	Specification
1	Microcontroller (MN)	STM32F103C8T6
2	Microcontroller (CN)	STM32F030F4
3	Módulo de RF	NRF24L01 2.4 Ghz
4	Módulo Bluetooth	HC-05
5	Infrared receiver	IRM-2638 38Khz
6	Light Sensor	BH1750
7	Solid State Relay SSR	SSR-25DA
8	Current Sensor	ACS7210
9	LED lamp	18 watt – 4500 – 6700 K

2.3 Functional Requierments

The design of the home automation device has been projected to fulfill specific functions that are aimed at solving the problems that exist around home automation systems, especially the formation of isolated systems or technological islands. The functional requirements implemented in the system were the following:

1. Supervision of the system through the MN: it maintains the values of the variables in the programmed ranges, executing complex algorithms and reporting system activity.

2. Monitoring of the voltage, current and lighting variables: it is carried out through the sensors arranged in each of the control modules.
3. Control of the intelligent LED lamp modes (on, off) and intensity regulation: it is carried out based on the sensor values and pre-established parameters.
4. Smart AC electrical load on and off control: carried out based on the sensor values and pre-established parameters.
5. Remote control function of LED lamp and outlet via infrared communication.
6. Remote control function via smartphone for LED lamp and outlet.
7. Communication with other parent nodes of a wireless sensor network [21].

2.4 Home Automation Prototype Architecture

A hierarchical distributed architecture has been proposed for the home automation subsystem, which, although it is part of a larger system, whose architecture is hybrid distributed, combines both hierarchical and heterarchical characteristics [18]. The architecture in this proposal is considered distributed because all the devices are intelligent and to a certain extent autonomous, which makes it possible to compare the MN with an intelligent agent and the CNs with a pseudo-agent, similar to a multi-agent system [21]. The upper part of the architecture shown in figure 3 is the global network of the system or higher level of the home automation network, which can be connected to a residential gateway for internet connection. The supervision and command level have the highest hierarchy of the control and lighting system, which has access, through a wireless communication system, to the control level, which is in charge of the controlled devices.

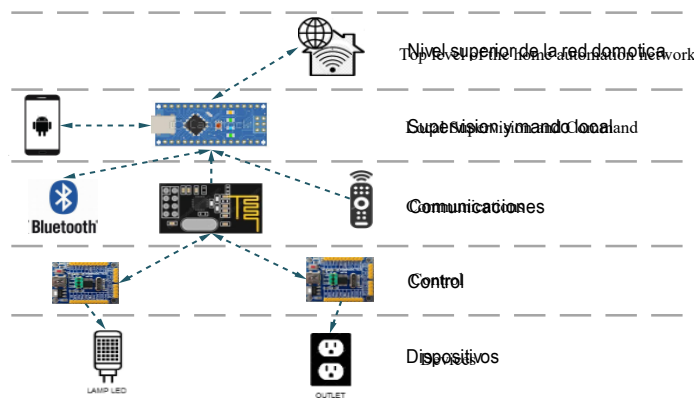

Figure 3. Home Automation Prototype's Architecture

2.5 Master Node's Architecture

The MN has as its central element a STM32F103C8T6 microcontroller that works with a voltage of 2.0 to 3.6 V, at a processing speed of 90 MIPS and has multiple internal resources and I / O ports for its operation. In addition, it has the low-cost NRF24L01 transceiver to communicate wirelessly with the CNs and an HC-05 bluetooth module that serves as an interface with the smartphone. It also has multiple I / O pins, digital and analog to allow the input or output of other devices. Figure 4 shows the distribution of this architecture.

2.6 Control Node's Architecture

The central element of the CN is the 32-bit STM32F030P4 microcontroller, which is powered with a voltage of 2.0 to 3.6 V and an 8 MHz crystal that provides a processing speed of up to 48 MIPS. It has a power interface with components according to the requirements of the actuator (led lamp: transistor TIP122; Outlet: SSR-25 DA) and the sensors that are in charge of transmitting the changes in the actuator variables. For communication with the MN there is a NRF24L01 transceiver and an IR module to detect the commands of a remote control; Figure 5 shows the architecture of the control nodes.

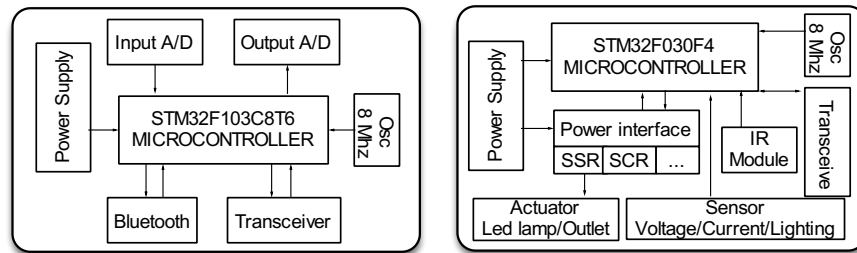

Figure 4. Master Node's Architecture **Figure 5.** Control Node's Architecture

3 General System UML-PN Modeling

In the previous section, the analysis of the proposed system has been developed and the characteristics, functions, and architectures of the system have been specified, thereby defining the hardware model of the system. From this result, the modeling of the system begins using UML (Unified Modeling Language) and PN (Petri Nets) [19]. With UML, the interaction of operations and tasks that allow the device to comply with the specifications and functions already defined in section 2.3 are systematically defined. PNs allow, based on UML modeling, to verify and validate the system, analyzing compliance with the PN properties.

3.1 Use Case Diagram

The use case diagram of the proposed system consists of 4 actors and six use cases, as can be seen in figure 6. The variable monitoring use cases are of type include, since they are execution Mandatory from system monitoring. The actors have been determined from the description of the system provided in section 2.1. The use cases have been derived from the functions of the system analyzed in section 2.3. The Remote Control and Smart Phone actors represent the user or technician who operates the system.

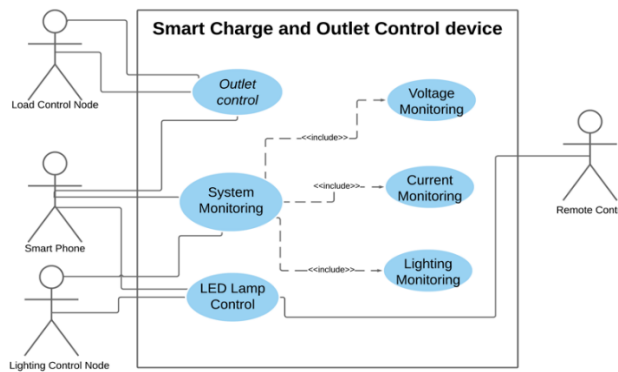

Figure 6. General Case of Use Diagram

3.2 Sequence Diagram

The sequence diagram of the system is shown in Figure 7, which has been developed from five objects that represent each of the components of the devices. The sequence starts in the MN, which is in charge of synchronizing the system processes. Each of the nodes is an autonomous device, which is why the exchange of messages is to carry orders or commands between the devices. The MN is in charge of initiating the dialogues and is awaiting the actions or requests that are notified to it through the wireless channels, to process the requirements and keep the system updated, according to the configurations generated by the user through the smart phone or the remote control.

3.3 States Diagram

The state diagram is used to define the set of system states in response to the events generated, which allows establishing the static behavior of the system. Figure 8 shows the state diagram developed for the system based on its use, sequence and behavior in the face of the different events that are generated due to the interaction of the MN with the other devices associated with the system.

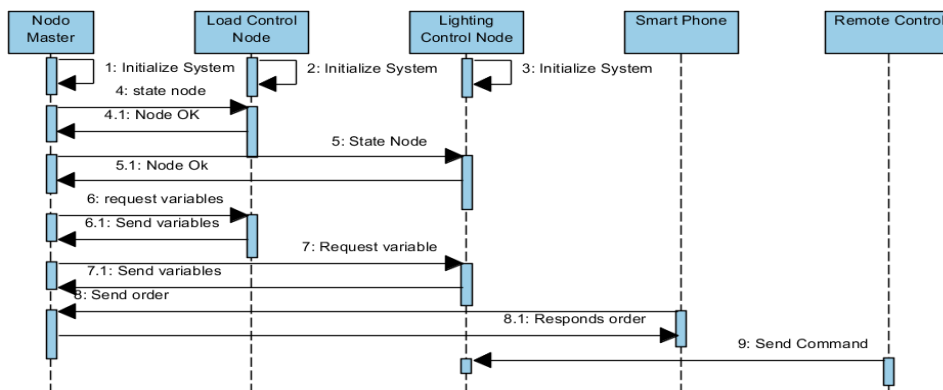

Figure 7. System sequence diagram

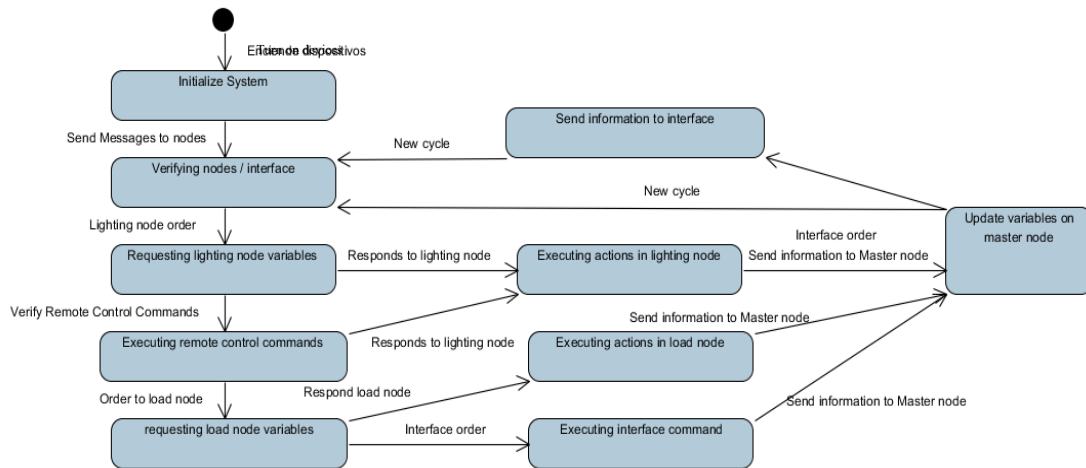

Figure 8. System state diagram

3.4 Petri Net

The Petri net (PN) of the proposed system has been elaborated from the UML modeling, with which the requirements of the device and its static behavior were defined. The PNs allow to describe the concurrent, sequential and synchronized events of the system [20], characteristics that the proposed model has and whose mathematical representation allows to validate the functionality of the system.

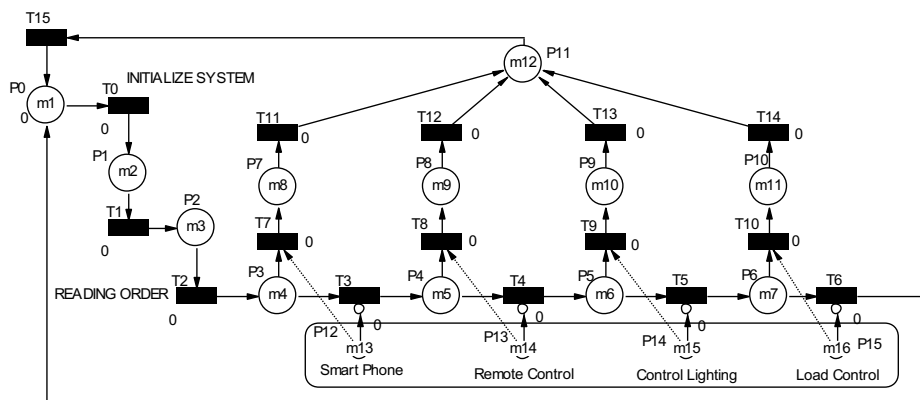

Figure 9. General Petri Net

Based on the PN of the system, an analysis is carried out to know the invariants of the system, the resulting equation of the general system and the behavior of the marks together with the transitions. Tables 2 and 3 show the results of the invariants of the places and the transitions.

The equation shows the PN that mathematically represents the general behavior of the system.

$$M(P0) + M(P1) + M(P11) + M(P12) + M(P13) + M(P14) + M(P15) + M(P2) + M(P3) + M(P4) + M(P5) + M(P6) = 1 \tag{1}$$

Based on this equation, it is determined that the PN works correctly, because only one brand passes through all the places at a time, which is the ideal in the system, and it is not appreciated that there are conflicts in the system. Possible conflicts between devices can be detected from the UML diagrams and corroborated with the PN analysis. Only if orders are sent from the different devices that the system has, will the sub-states take place where the actions requested by the intelligent module are carried out to meet user requirements.

Transitions	Range (0-1)
0	1
1	1
2	1
3	1
4	1
5	1
6	1
7	0
8	0
9	0
10	0
11	0
12	0
13	0
14	0
15	1

Places	Range (0-1)
0	1
1	1
2	1
3	1
4	1
5	1
6	1
7	0
8	0
9	0
10	0
11	1
12	1
13	1
14	1
15	1

4. Experimental Tests

Once the system has been modeled, is implemented using the STM32F103C8T6 (MN) and STM32F030P4 (Lighting and Charging CN) microcontrollers, and using the C / C ++ language on the Keil development platform. Figures 10, 11 and 12 show the prototypes of the MN, load CN and the 20W LED lamp controlled by the lighting CN.

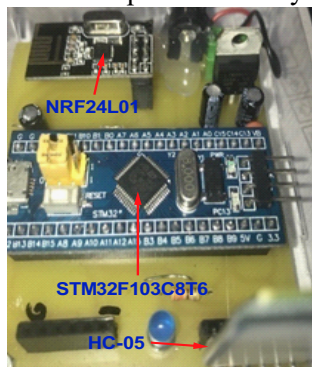

Figure 10. Master node

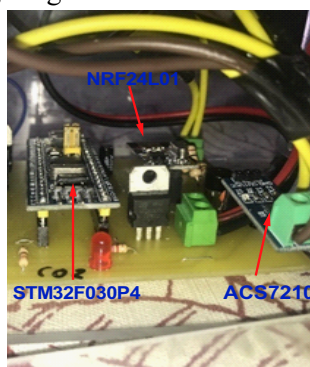

Figure 11. Outlet node



Figure 12. 20W Lamp LED

4.1 Infraed test

For this test, the precision of sending commands from the remote control to the lighting CN is obtained. It is arranged to send commands to the CN and a 100 lighting of this have been registered as a how many have been received and executed correctly in the CN. Table 4 shows the values depending on the distance, where it can be seen that, for more than 5 m, the commands are received incorrectly and from 7 m they do not reach the receiver. These limitations are specific to this communication, although reception distances can be improved by increasing the cost of the device.

4.2. Radiofrequency Test

The radio frequency test is based on the precision of the communications between the devices considering the distance between them [21]. Since the device is designed for a home automation

environment, it has been considered a block wall that separates the devices, and the physical distance between them. In a computer, through an interface with the MN, the values shown in table 5 have been recorded, obtained with the NRF24L01 module, in which it can be seen that communication is very good up to 8 meters, and that at from 10 meters onwards, transmission errors begin to increase, considerably after 12 meters.

4.3 Bluetooth Test

This test has been carried out between the master node and a smartphone through an interface based on an App developed for the Android operating system. Through this interface you can access all the functions, including the configuration of the devices. Similar to the previous tests, 100 commands have been sent and the number of successful communications has been recorded. Table 6 shows the results obtained, where it can be seen that, up to a distance of eight meters, very good communication is obtained. From 12 meters the rate of communication errors is considerably increased.

Table 4. IR Communication

Distance [m]	Accuracy [%]
1	100
2	100
3	100
4	100
5	32
6	14
7	0
8	0
9	0
10	0

Table 5. RF Communication

Distance [m]	Accuracy [%]
1	100
2	100
3	100
4	100
5	100
6	95
8	92
10	71
12	55
15	35

Table 6. BT Communication

Distance [m]	Accuracy [%]
1	100
2	100
3	100
4	100
5	95
6	83
8	80
10	71
12	51
15	28

5. Conclusions

In this research work, a set of wirelessly communicated smart devices has been proposed that have been oriented to use in home automation systems. This proposal aims to control lighting and control electrical loads powered by alternating current (AC). Low-cost components such as microcontrollers, transceivers, sensors and actuators have been used for its implementation. In its design, a new methodology based on UML-PN has been proposed for the projection and validation of the system; This methodology has allowed to implement the design of an intelligent device based on fully functional wireless communications. UML has been used to systematically project and design the entire development process, specifying the internal details of the system, including the interaction between devices. The PN, in addition to allowing the verification and validation of the system, has served to simulate the system and determine the dynamic behavior, detecting early, through the properties of the Petri net, problems of concurrency, sequentially and synchronism. The use of 32-bit microcontrollers, added to the C / C ++ programming language, provide a very solid and efficient tool for the implementation of microprocessor-based systems, whose code writing process is complemented by the modeling and simulation of the UML methodology. -PN.

The developed application constitutes a product of the proposed methodology and constitutes a subsystem that is part of a comprehensive home automation system, which corresponds to the energy saving function. The proposed model is aimed at reducing isolated home automation elements, very common in current home automation proposals.

6. References

- [1] Molina González, L. (2010). Instalaciones Domóticas. 1era Edition. Editorial McGraw-Hill/ Interamericana de España, S.A. 200 pages. ISBN: 8448171446.
- [2] Nuñez-Alvarez, J. R.; Benitez-Pina, I.; Llosas-Albuérne, Y. (2020). Communications in Flexible Supervisor for Laboratory Research in Renewable Energy. *IOP Conf. Ser.: Mater. Sci. Eng.* Vol 844. 012016. doi:10.1088/1757-899X/844/1/012016
- [3] Moro Vainilla, M. (2011). Instalaciones Domóticas. Electricidad-Electrónica. Libro. Editorial Paraninfo. 208 pages. ISBN: 9788497328586.

- [4] Sita, V.; Avram, C.; Dobra, M.; Astilean, A. (2018). Delay time Petri Nets based decision model to decrease the risk of false security alarms. *2018 IEEE International Conference on Automation, Quality and Testing, Robotics (AQTR)*, Cluj-Napoca, 2018, pp. 1-6, doi: 10.1109/AQTR.2018.8402721.
- [5] Nuñez, J. R.; Mestre, J.; Cabello, J. J.; Dominguez, H.; Fong, J.; Benitez, I.; Pupo, L.; Oliveira, D. (2020). Design of a Fuzzy Controller for a Hybrid Generation System. *IOP Conf. Ser.: Mater. Sci. Eng.* Vol 844. 012017. doi:10.1088/1757-899X/844/1/012017
- [6] Palomino, K.; Reyes, F.; Nuñez, J.; Valencia, G.; Herrera, R. (2020). Wind Speed Prediction Based on Univariate ARIMA and OLS on the Colombian Caribbean Coast. *Journal of Engineering Science and Technology Review.* 13 (3), pp. 200 - 205. doi: 10.25103/jestr.133.22
- [7] Barrozo, F. A.; Valencia, G.; Obregon, L. G.; Arango-Manrique, A.; Nuñez Álvarez, J. R. (2019). Energy, Economic, and Environmental Evaluation of a Proposed Solar-Wind Power On-Grid System Using HOMER Pro®: A Case Study in Colombia. *Energies.* Vol 13 (7). pp 1662 doi:10.3390/en13071662
- [8] Sugiharto, W.; Ghozali, M.; Murti, A.; Nindyasari, R.; Hakim, M. (2018). Multiple Smart Home Controlling System using Database Replication Method. *1st International Conference on Computer Science and Engineering Technology.* Universitas Muria Kudus, Kudus, Indonesia, 2018, doi: 10.4108/eai.24-10-2018.2280553.
- [9] Zouai, M.; Kazar, O.; Haba, B.; Saouli, H. (2017). Smart house simulation based multi-agent system and internet of things. *International Conference on Mathematics and Information Technology (ICMIT)*, 2017, pp. 201-203, doi: 10.1109/MATHIT.2017.8259717.
- [10] Afonso, B. L.; Neto, J. P.; Andrade, P.; Tibério C. J.; Loureiro, G.; Campos, A. L; Fernandez, M. (2020). Fuzzy Logic Applied to eHealth Supported by a Multi-Agent System, SpringerLink. <https://www.springerprofessional.de/en/fuzzy-logic-applied-to-ehealth-supported-by-a-multi-agent-system/15906048>.
- [11] Pau, G.; Salerno, V. M. (2019). Wireless Sensor Networks for Smart Homes: A Fuzzy-Based Solution for an Energy-Effective Duty Cycle. *Electronics.* Vol. 8, 131. <https://doi.org/10.3390/electronics8020131>
- [12] Rodriguez, M. (2016). Sensor arrays for Enology applications: Using nanoscience for grape analysis. Tesis Doctoral. Departamento de Química, Física y Química Inorgánica. Universidad de Valladolid. DOI: 10.35376/10324/18886
- [13] Haqiq, A; Bounabat, B. (2017). Using BECAMEDA method to specify and verify a smart home system. *Proceedings of the 2017 International Conference on Smart Digital Environment.* pp 42-47. <https://doi.org/10.1145/3128128.3128135>
- [14] Martín Domínguez, H.; Sáez Vacas, F. (2006). Domótica: un enfoque sociotécnico. Book. 1th Edition. Madrid: Fundación Rogelio Segovia para el Desarrollo de las Telecomunicaciones. ISBN: 84-7402-335-1
- [15] Ito, K., *et al.*, (2019). Home Automation Platform Using Interaction-Based Sensing. *2019 IEEE International Conference on Consumer Electronics (ICCE)*, Las Vegas, NV, USA, 2019, pp. 1-2, doi: 10.1109/ICCE.2019.8661918.
- [16] Santos, R.; Ordínez, L.; Eggly, G. (2016). El enfoque de Cajas Negra y Blanca para la enseñanza de sistemas embebidos, *2016 IEEE Biennial Congress of Argentina (ARGENCON)*, Buenos Aires, Argentina, 2016, pp. 1-7, doi: 10.1109/ARGENCON.2016.7585294.
- [17] Valenzuela, S. S.; Holgado, J. A. (2008). Control Domótico del Hogar a través de una Plataforma de Servicios Distribuida basada en JXTA. SDS 2008, pp. 203-218. ISBN: 978-84-96856-71-4
- [18] Cerrada, M.; Aguilar, J.; Cardillo, J.; Faneite, R. (2006). Agent-based design for fault management system in industrial processes. *Revista Técnica de la Facultad de Ingeniería.* Universidad del Zulia, vol. 29, pp. 258-268
- [19] ARM (2020). Keil Embedded Development Tools for Arm, Cortex-M, Cortex-R4, 8051, C166, and 251 processor families. <https://www.keil.com/>
- [20] Gutiérrez, H.; Muñoz, A. (2013). Ladder diagram generation using Fuzzy Petri-Nets. *Revista Vínculos.* Vol. 10 (2), p. 369-380. DOI. 10.14483/2322939X.6523
- [21] Mendoza, E.; Fuentes, P.; Benítez, I.; Reina, D.; Nuñez, J. (2020). Red de sensores inalámbricos multisalto para sistemas domóticos de bajo costo y área extendida. *Revista Iberoamericana de Automática e Informática industrial.* Vol. 17 (4). doi: 10.4995/riai.2020.12301